

Emerald 850 Cleanout Unit

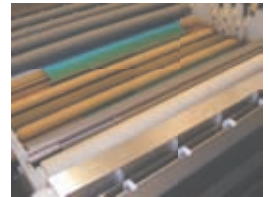
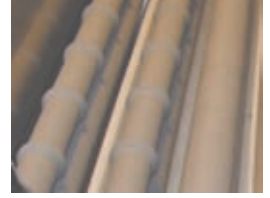

Standard features include:-

- Chiller unit
- Fill pump
- Installation kit
- Adjustable pre-heat temperatures to accommodate up to 4 individual plate sizes
- Cycling timer
- Small footprint
- Minimum plate length of 255mm (10")
- Heavy duty drive
- Ø50mm rollers
- Installation through standard single doorway
- Narrow width alternative available
- **ZERO water consumption**

NES Worldwide Ltd (UK)

Unit 4-8 Napier Place Stephenson Way Industrial Estate
Thetford Norfolk IP24 3RL
Tel: 01842 765128 Fax: 01842 765267
e-mail: info@nesworldwide.com

NES Worldwide Inc (USA)

3, Progress Avenue
Westfield, MA 01085
Tel: 413 562 8000 Fax: 413 564 0281
e-mail: info@nesworldwide.com

Emerald 850 Cleanout Unit

Specifications



Designed to give reliable and efficient cleanout and gumming of Violet chemistry free CTP plates within a small footprint, the Emerald range retains the durability, high quality and ease of operation associated with all NES pre-press equipment.

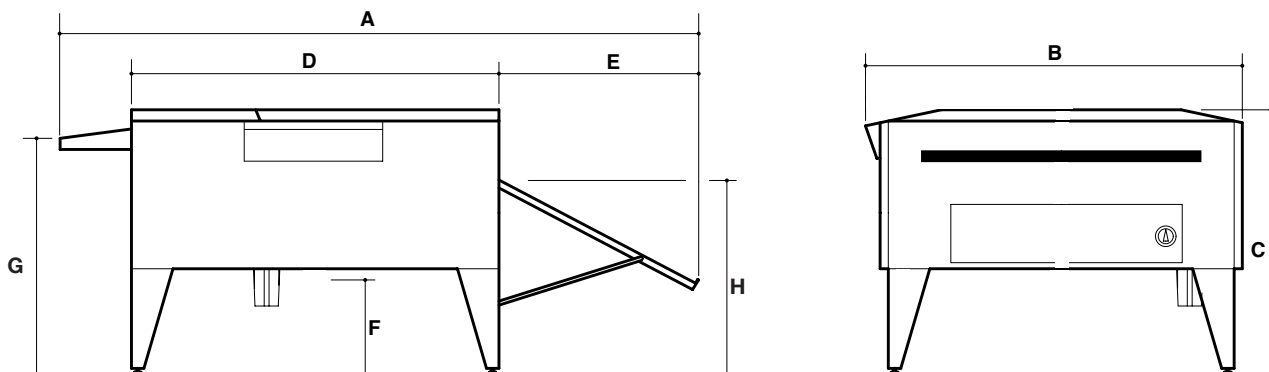

Dimensions:

A	2731mm
B	1410mm
C	1130-1160mm
D	1395mm
E	1015mm
F	430-460mm
G	910-940mm
H	900-930mm

Weight (Uncrated): 300 kg

Plate Sizes

Max. plate width: 850mm (33.5")
Min. plate length: 255mm (10.0")
Plate thickness: 0.15mm (0.006") - 0.30mm (0.012")

Plate Types Single sided Violet Chemistry Free plates.

Plate Cleaning Speed

30 second dwell @ 0.8m/min.
25 second dwell @ 1.0m/min.

Gum

Type: As recommended by plate and chemical representative.
Capacity: 27 litres
Overflow: To replenisher bottle.
Replenishment: Per plate – adjustable 0-180 seconds (0-600ml).
Temperature: Adjustable between 18-35°C (64°-95°F)
Temperature maintained within $\pm 1^\circ\text{C}$ ($\pm 2^\circ\text{F}$) tolerance only when used in conjunction with chiller unit.

Electrical Requirements

220-240 VAC 1N+PE 50/60Hz 30A or 380 VAC 3-phase 16A

Optional Equipment

- Mechanical Interfaces
- Remote Pre-heat selector/E-stop
- Drip tray (slide-in/stand-in/container)
- Delivery table (short/standard)
- Wireless container level alarm
- Recommended spares kit
- Input table (short/standard/long)
- Electrical interface to most image setters
- Auto gum top-up
- Installation wheel kit
- Plate Stacker

NES Worldwide Ltd (UK)

Unit 4-8 Napier Place Stephenson Way Industrial Estate
Thetford Norfolk IP24 3RL
Tel: 01842 765128 Fax: 01842 765267
e-mail: info@nesworldwide.com

NES Worldwide Inc (USA)

3, Progress Avenue
Westfield, MA 01085
Tel: 413 562 8000 Fax: 413 564 0281
e-mail: info@nesworldwide.com