

NE 28 Plate Stacker

The NES full line of flexible, reliable plate stacking systems speeds workflow for all printers working in both digital and conventional platesetting environments.

This fully-automatic stacker is one of many advanced plate-handling solutions offered by NES Worldwide. Call us, or visit our web site at www.nesworldwide.com to learn how our expert staff can help put the right system—at the right price—into your print shop.



Standard Equipment Includes:

- Fully-automatic plate stacking
- Supports plates of multiple gauges: 0.005 – 0.020"
- Solid steel construction for reliable operation
- Electrical CUL® tested and certified
- Made in USA
- Adjustable height accommodates most processors
- Optional plate trolley facilitates transfer of plates from prepress to press room
- 120V, 5A - 50/60 Hz



Worldwide Presence. Local Attention.



Specifications:

NES Worldwide is dedicated to providing products and services that will speed your workflow. Our full range of plate stackers automates the task of handling plates as they exit your plate processing system. Solid and reliable, all units in this product line are constructed of the highest quality materials. Our plate stackers operate in demanding production environments and without the intervention of your staff—maximizing productivity and throughput.

Our family of highly flexible plate stacking devices can accommodate plates of varying sizes. With a modest footprint and modular stacking trolley, the systems securely abut your conventional or digital plate processor, making it an ideal solution for busy prepress environments. Perfect for overnight or unattended operation, these plate stackers free your staff to work on other—more pressing—tasks.

For automated plate handling that will speed your workflow and maximize productivity, our family of plate stacking systems is an excellent addition to your plate-handling solution.

Installation, Service, Parts, Sales, Refurbishment

The team at NES Worldwide is dedicated to one goal: making your business run smoothly. We offer straightforward, expedient, customized solutions to all of your plate-handling requirements – from new and refurbished equipment, to service, parts and installation.

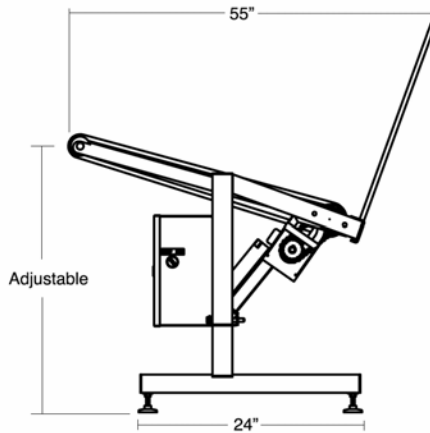
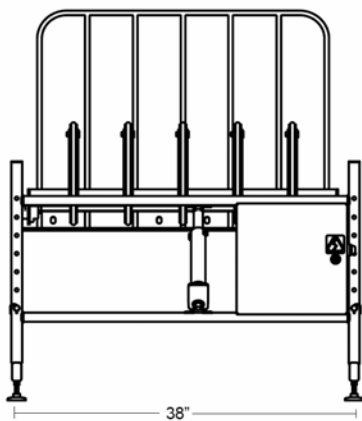

Specifications:

NE 28

Maximum plate	30" L x 32" W	(762mm x 815mm)
Minimum plate width	7"	(180mm)
Footprint	55" x 34"	(1397mm x 865mm)
Weight	150 lbs.	
Capacity	Up to 25 plates	
Adjustable height	29" to 44"	(737mm to 1118mm)
Electrical requirements	120V, 50/60Hz, 5A	(Standard wall outlet cord)



Optional Plate Trolley

All units are electrical UL® and CUL® tested and certified.

*Options

Plate trolley – 35 lbs.
220V, 5A – 50/60Hz Electrics



Worldwide presence.
Local attention.

NES Worldwide Inc.

3 Progress Avenue
Westfield, MA 01085, USA
Telephone: 1 413 562 8000
Fax: 1 413 564 0281
E-mail: info@NESworldwide.com

NES Worldwide Ltd.

Unit 4-6 Napier Place
Stephenson Way Industrial Estate
Thetford, Norfolk IP24 3RL, UK
Telephone: 44 (0) 1842 765128
Fax: 44 (0) 1842 765267
E-mail: info@NESworldwide.com