

Chiller One

Closed Loop cooler

Operators Guide



Northeast Equipment Services Ltd
Unit 4, Napier Place
Stephenson Way Industrial Estate
Thetford, Norfolk IP24 3RL

Telephone No: +44 (0) 1842 765128
Fax No: +44 (0) 1842 765267

Copyright © 2003 **Northeast Equipment Services Ltd**

Date of publication January 2004
Rev. A Part No. 100-001212

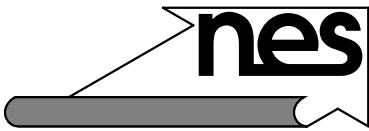

Chiller One Closed Loop cooler

Section	Sub Section	Page
1.0	Safety and Environmental Protection Summary	3
2.0	Intoduction	3
3.0	Installation Procedure	3
4.0	Adjusting Set Point.....	4
5.0	Maintenance	5
6.0	Dismantling/Decommissioning Procedure.....	5
7.0	Spares.....	5
8.0	Troubleshooting	6

This guide covers the operation and day-to-day maintenance for the Chiller Unit. It has been written and illustrated using the best possible information available at the time of publication. The guide should be regarded as part of the equipment and should be kept with it throughout its working life.

Any differences between the guide and the equipment reflect improvements introduced after the publication of the guide. Any amendments received should be recorded below and incorporated in the relevant part of the guide.

Changes, technical inaccuracies and typographical errors will be corrected in subsequent revisions.

As part of our policy for continuous product development and improvement, NES Ltd reserves the right to make changes in design and specification without notice.

1.0 Safety and Environmental Protection Summary

All operators and customer maintenance personnel should familiarise themselves with this guide before using or servicing this equipment



Caution

This Unit has been designed for use as a Cooling and Recirculating Unit on Northeast Equipment only, and should NOT be used for any other purpose.

Any maintenance, servicing or adjustments must only be carried out by suitably skilled or properly instructed/supervised personnel. When self-servicing this unit incorrect performance or incorrect re-assembly can cause personal injury.

2.0 Introduction

This Water Chiller is capable of extracting 950 watts per hour with an ambient temperature of 32Deg C.

It is simple in operation and maintenance free with the exception of condenser cleaning. The Chiller operates using a shell and tube evaporator. A flexible shell eliminates the need for anti-freeze and damage caused by freeze ups. Maximum cooling is available almost immediately on start up.

3.0 Installation Procedure

1. Unpack the unit from its transportation packing and visually check for any signs of damage.
2. Attach the bottom hose from the chiller unit to Chiller In on the processor, attach the top hose from the chiller unit to Chiller Out on the processor (see Fig. 1).
3. Remove the water filler cap on the top of the cooler and fill the container to the 1500ml mark.
4. Check the source voltage of the outlet using a voltmeter. Only the voltage indicated on the unit Serial No./Rating Plate is to be connected to the chiller.
Ensure electrical outlet is dedicated (no other equipment on the same circuit breaker).

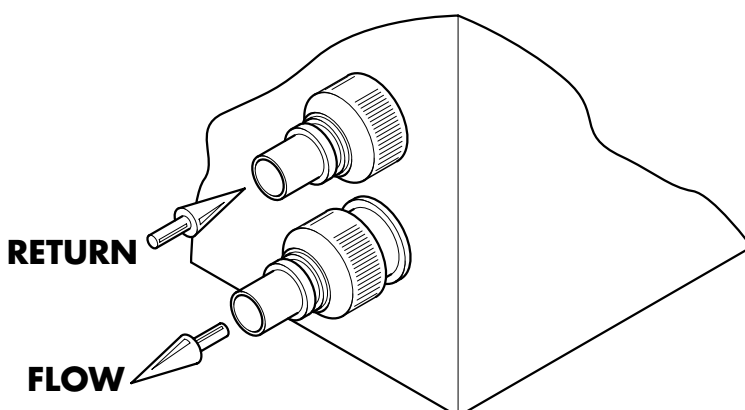

Fig. 1



Fig. 2

3.0 Installation Procedure (continued)

5. Fit suitable electrical plug.



Warning

This equipment must be earthed.

The Wires in this Mains Lead are coloured in accordance with the following Code:

Green and Yellow	Earth
Blue	Neutral
Brown	Live

As the Colours of the Wires in the Mains Lead of this Appliance may not correspond with the Coloured Markings identifying the Terminals in the Plug to be fitted, proceed as follows:

- a. The Wire which is Coloured Green and Yellow **MUST** be connected to the terminal in the plug that is marked with the letter 'E' or by the earth symbol:  or coloured Green or Green and Yellow.
 - b. The Wire which is Coloured Blue **MUST** be connected to the terminal in the plug that is marked with the letter 'N' or Coloured Black.
 - c. The Wire which is Coloured Brown **MUST** be connected to the terminal in the plug that is marked with the letter 'L' or Coloured Red.
6. Connect to the mains and switch on the chiller.
 7. Continue to top up the header tank to the 1500ml mark until the cooling tube circuit is full.
Note: The header tank is fitted with a float switch to prevent damage to the chiller by operating without water. If the chiller fails to operate, check the water level in the header tank.
 8. Refit the filler cap and check for obvious leaks.

4.0 Adjusting Set Point

The chiller is fitted with an electronic temperature controller to maintain the chiller temperature. The controller is factory set when supplied with a processor and should not require adjustment.

If adjustment is necessary, use the following procedure:

1. Press the "set" button until current set point flashes on display (see fig 3).
2. Press the UP or DOWN arrow key to the required set point.
3. Press the "set" button to enter new set point.

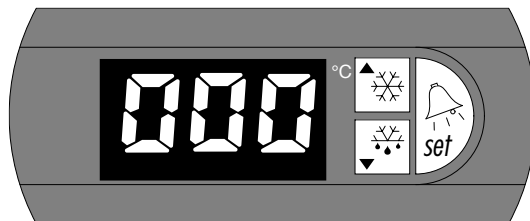
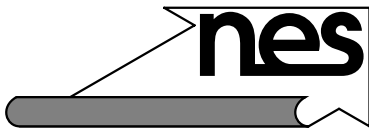

Fig. 3



Chiller One Closed Loop cooler

5.0 Maintenance

It is not recommended that the End User makes any adjustments or carries out any Maintenance other than:

- a. Check the mains lead and plug visually for condition.
- b. Check the unit and its pipework for evidence of leaks.
- c. Check that the condenser grill and vents are not choked or obscured.

Annually (by a competent Service/Maintenance Engineer)

- a. Isolate unit from Mains Electricity Supply.
- b. Remove any extraneous debris from the unit or its casing preferably using a vacuum cleaner or brush.
- c. Check unit for electrical safety.

6.0 Dismantling/Decommissioning Procedure

1. Switch off the chiller.
2. Switch off the unit at the mains electrical supply.
3. Remove the chiller flow & return hoses.
4. Tip the chiller towards the outlets to drain water from the evaporator and pump.
5. The chiller is now ready for transportation.

7.0 Spares

Item No	Description	Part No.
1	Compressor, 60hz	100-001042
or	Compressor, 50hz	100-001216
2	Condenser, 60hz models	100-001043
or	Condenser, 50hz models	100-001218
3	Condenser Fan Assy, 60hz	100-001044
or	Condenser Fan Assy, 50hz	100-001219
4	Temperature Controller	100-001045
5	Controller Probe	100-001046
6	Water Pump	100-001217
7	Water Tank	100-001047
8	Castor	100-001048
9	Shell & Tube Evaporator Assy	100-001049

Please quote Model & Serial No. when ordering spares.

8.0 Troubleshooting



Attention

Any corrective maintenance must only be carried out by suitably skilled or properly instructed/supervised personnel.

The Troubleshooting section is a table which lists some possible problems, causes and remedies for chiller malfunctions.

Use the Troubleshooting table to locate and solve any specific chiller malfunctions.

To correct a problem, do the following:

- Find the symptom which best describes your problem.
- Match the symptom with a probable cause and solution.
- Correct the problems by trying each solution.

NOTE: Troubleshooting cannot be performed in a thorough manner unless the chiller is operated under recommended specifications.

